

FRESHWATER SYSTEM INSTALLATION & STARTUP GUIDE

MODEL: NKD-M

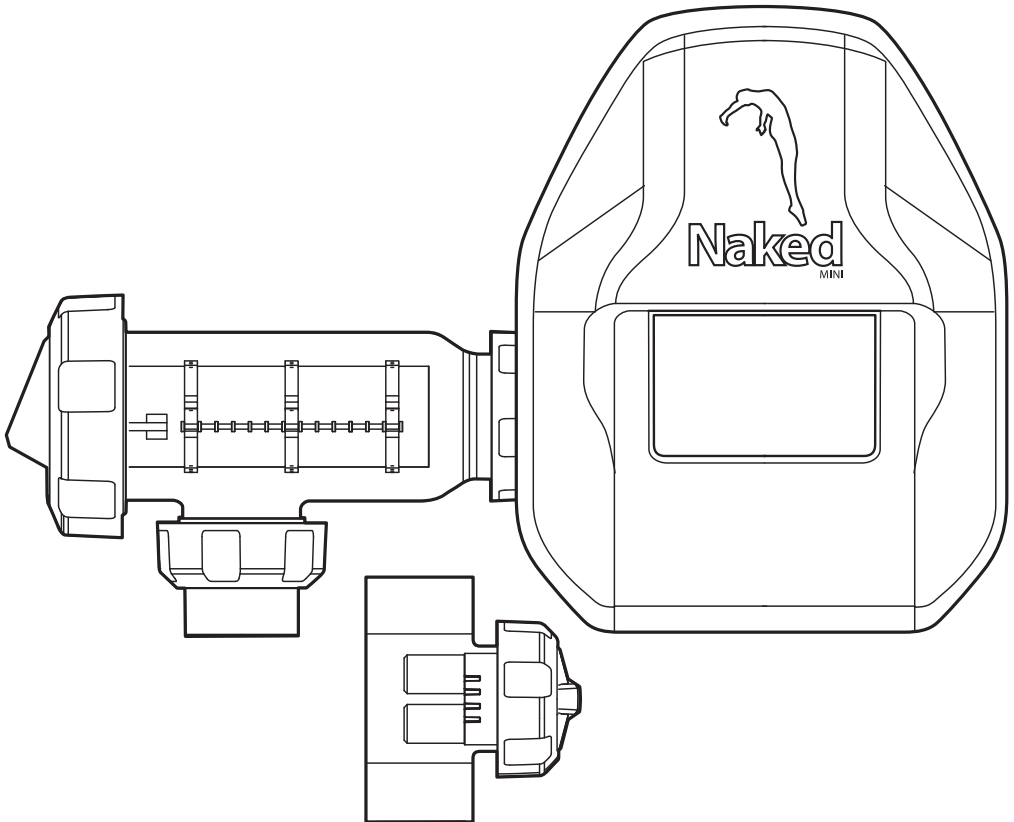

NOTE:

1. READ THIS DOCUMENT PRIOR TO INSTALLATION. IMPROPER INSTALLATION WILL VOID WARRANTY.
2. PRODUCT ONLY TO BE INSTALLED & SERVICED BY A SUITABLY QUALIFIED PROFESSIONAL.
3. THIS MANUAL CONTAINS IMPORTANT INFORMATION. ONCE INSTALLATION IS COMPLETE INSTALLER MUST PROVIDE THIS MANUAL TO OWNER/OPERATOR TO STORE IN A SAFE PLACE.



IMPORTANT - PLEASE READ!

This guide contains important information about the installation, operation and safe use of this product. When installing and using this electrical equipment, basic safety precautions should always be followed. Failure to follow safety warnings and instructions in this manual can result in serious injury and/or damage to the equipment. Read and follow all warning notices and instructions that are included in this guide.

The Control Unit internally contains live components. There is a danger of electric shock if opened. If the power cord is damaged then the manufacturer, their agent or a similar qualified person in order to avoid a hazard, should replace it. The product shall be installed according to AS/NZS 3000 wiring rules. It shall be installed outside the pool zone.

To reduce the risk of accidents or incidents, service on the unit should only be performed by a qualified pool service professional and not operated by children under 18 years of age.



**WHEN MIXING ACID WITH WATER:
ALWAYS ADD ACID TO WATER. NEVER ADD WATER TO ACID.**



DO NOT PLUG UNIT IN IF CARTON HAS BEEN WET.



GAS BUILD-UP CAN OCCUR WITH IMPROPER WIRING.

To reduce the risk of personal injury, the Control Unit is designed so that the OXI Cell and ION Rods will only receive power when the pool pump is on. Otherwise possible gas build-up can occur. If the pump is not installed to the AC Socket (pump outlet) on the Control Unit, the installer **MUST** ensure that the OXI Cell and ION Rods are never energised when the pool pump is OFF or water is not flowing through the unit.

Specifications subject to change without notice.

The contents of this manual are the exclusive copyright of Naked Pools and may not be reproduced without written permission. © 2026

Whilst every care was taken in preparation of this document, Naked Pools accepts no responsibility for the accuracy of the information supplied.

FRESHWATER SYSTEM | PARTS SUMMARY

FOR THE BUILDER / INSTALLER

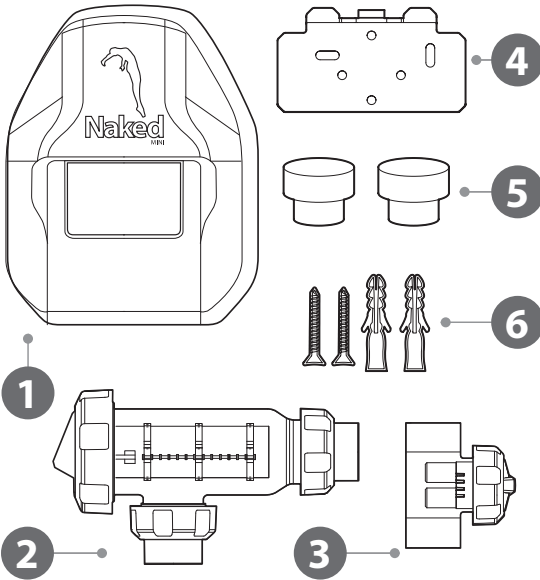

- 1 NKD-M Freshwater Control Unit
- 2 Oxidiser Housing with Unions
- 3 Ioniser Housing
- 4 Wall Mounting Bracket
- 5 50/40mm Reducing Bushes (x2)

FOR THE CUSTOMER

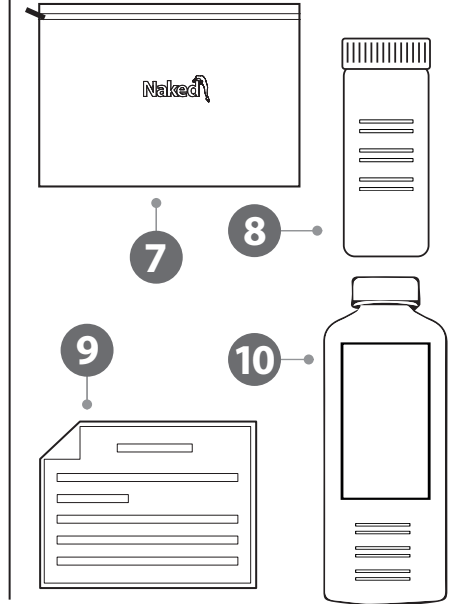

- 6 Wall Plugs & Mounting Screws (x2)
- 7 Handover Bag
- 8 Naked 3-in-1 Test Strips
- 9 System User Guide
- 10 Naked Water Test Bottle

TOOLS REQUIRED

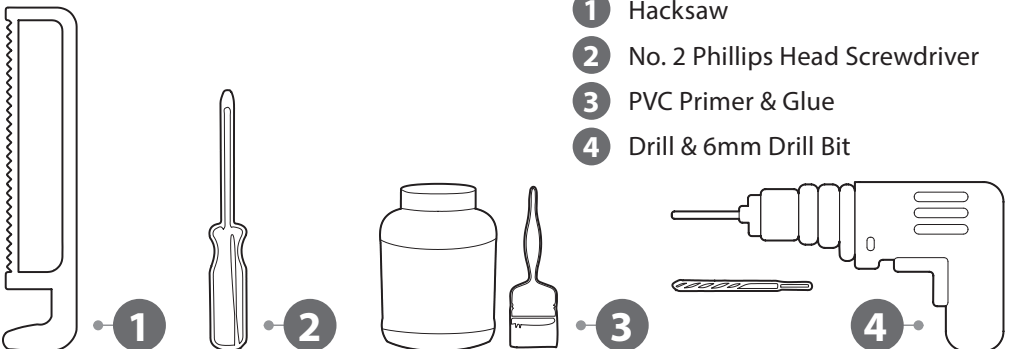

- 1 Hacksaw
- 2 No. 2 Phillips Head Screwdriver
- 3 PVC Primer & Glue
- 4 Drill & 6mm Drill Bit

TYPICAL SYSTEM INSTALLATION

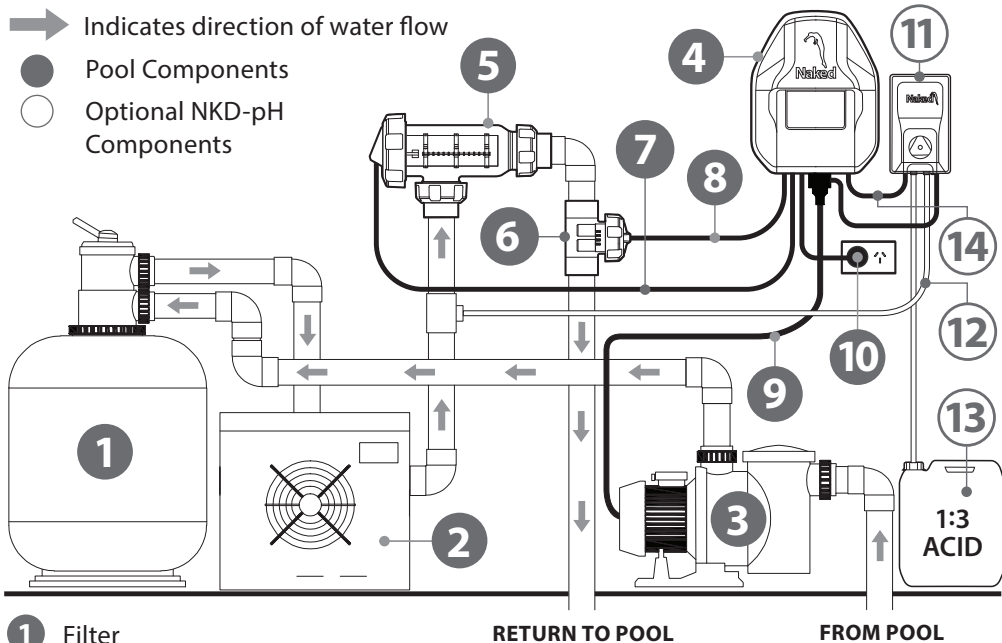

⚠ Before you start:

- We **DO NOT** recommend the use of valves on the inlet or outlet of the Cell Housings. If you do use a valve then it is important to ensure that the valve cannot deadhead (lock closed) while the pump is running. It is the installer's responsibility to ensure some form of flow control is installed in this instance and it disables the pump.
- **ALWAYS** ensure that pipe work and equipment do not allow gases generated to collect and build up in any part of the installation.
- **DO NOT** apply priming fluid to the Cell Housings, it is not needed and may react with the plastic.

INSTALLATION | OXI & ION CELL HOUSINGS

⚠ Before you start:

- A Venturi Pipe is incorporated within the OXI Cell Housing designed to eliminate any possible gas build up, although it is always recommended to ensure proper installation to eliminate this from happening.
- The Cell Housings must be installed in the **RETURN** pipework to the pool. They must always be installed **AFTER** the filter, gas heater, solar heating or heat pump. The ION Cell can be installed either before or after the OXI Cell.

CELL HOUSING CONFIGURATION OPTIONS

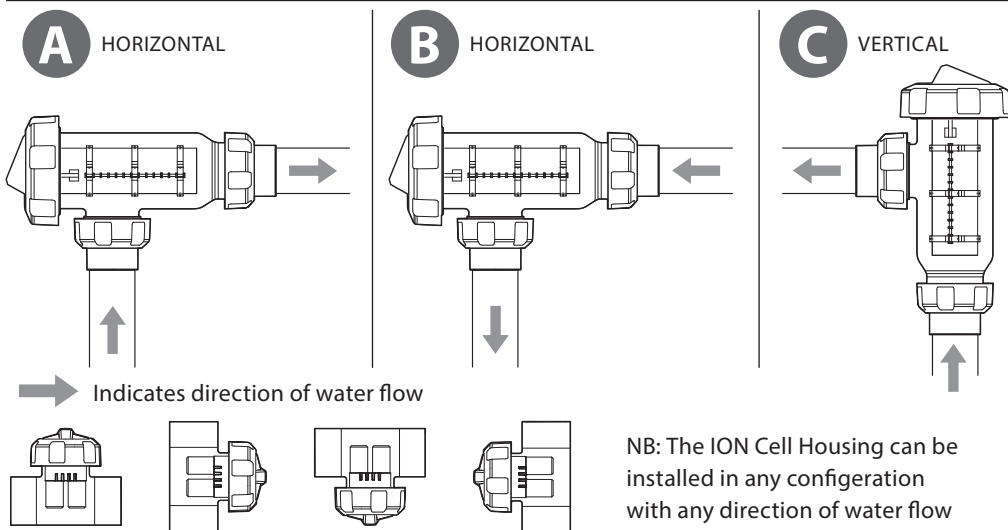

INSTALLATION STEPS (Refer to Typical System Installation diagram)

- STEP 1** Connect the OXI Cell Housing horizontally (A or B) in the return line to the pool using high pressure PVC glue. The OXI Cell Housing can be mounted vertically (C) but provision must be made for a gas trap.
- STEP 2** Check that the O-rings are clean, greased with silicone grease (**DO NOT** use petroleum based jelly) and securely located in the Cell Housings.
- STEP 3** Fit the OXI Cell and ensure the Locking Ring is firmly tightened by hand.
DO NOT USE A TOOL TO TIGHTEN
- STEP 4** Connect the ION Cell Housing in the return line to the pool using high pressure PVC glue. Fit the ION Cell and ensure the Locking Ring is firmly tightened by hand.
DO NOT USE A TOOL TO TIGHTEN
- STEP 5** Connect the OXI and ION cables to the control unit.

INSTALLATION | CONTROL UNIT

Before you start:

- The Control Unit has an Ingress Protection Rating of IP23 enabling it to be installed outdoors. Regulations require that the Control Unit shall be installed outside the pool zone. The Control Unit shall be installed according to AS/NZS 3000 wiring rules.
- The Control Unit should be installed in a well ventilated position, ideally away from sunlight and rain to prolong life and at least 1m above ground to prevent run off water entry.
- Ensure that the Control Unit is not stored near chemicals, fertilisers or in a closed unventilated shed with similar products as the fumes will cause excessive corrosion and damage to the internals of the Control Unit and may void warranty.
- When mounting the Control Unit on a post it is recommended to install a flat panel of at least the same size or larger to act as a waterproof backing plate.
- Mounting the Control Unit horizontally or leaving it on the ground will void all warranty.
- The Control Unit should be mounted no further than 1.5 metres from the Oxidiser & Ioniser Cell Housings for ease of operation.
- The pump rating must **NOT** exceed 8 Amps.

INSTALLATION STEPS (Refer to Typical System Installation diagram)

STEP 1 Attach Wall Mounting Bracket in the desired location for Control Unit using Wall Plugs and Mounting Screws provided.

STEP 2 Ensure the OXI and ION plugs are connected to the Control Unit ensuring a **FIRM CONNECTION**.

STEP 3 Plug the Control Unit 3 pin plug into a suitable weatherproof RCD protected 10amp outlet and then plug the pump power cable into the 3 pin AC Socket located at the bottom of the Control Unit.

STARTUP | BALANCE THE POOL WATER

⚠ Before you start:

- **ADD REQUIRED CHEMICALS AND SALT/MINERALS BEFORE STARTING THE NAKED SYSTEM.**
- Recommended TDS Levels are 800-1200ppm meaning salt levels are typically 500-700ppm only.
- If using **MINERAL** salts, allow **20-30% more** minerals based on the pool salt chart below.
- **DO NOT** add Cyanuric Acid to the pool.
- **DO NOT** add Stabilised Chlorine to the pool.
- **DO NOT** add Copper based Algaecides to the pool.
- **NEVER** add Salt or Minerals directly to the skimmer box.

Before starting the Naked System balance the pool water using the calculators in the Naked App (download using the QR code on the back cover) or use the information below:

WATER BALANCE GUIDELINES - Ideal Levels

(Always refer to your pool manufacturer's guidelines)

Pool Type	pH	Total Alkalinity	Calcium Hardness
Concrete	7.4 - 7.6	80 - 150ppm	200 - 250ppm
Fibreglass or Vinyl	7.2 - 7.4	80 - 120ppm	80 - 200ppm

Salt/Mineral

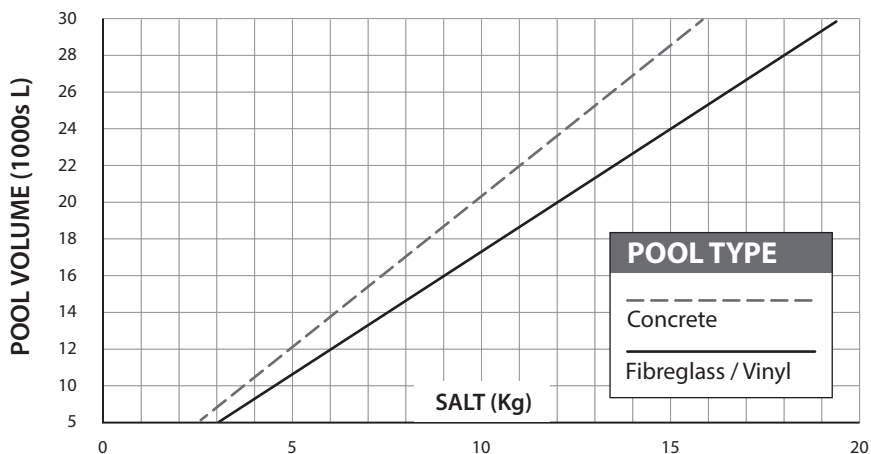

STARTUP | PROGRAMMING THE SYSTEM



Did you know?

The digital display on the Control Unit will typically explain each step and how to adjust or save the desired setting.

Programming the Naked System is completed in 6 simple steps using the following controls which are located in the centre of the Control Unit keypad :

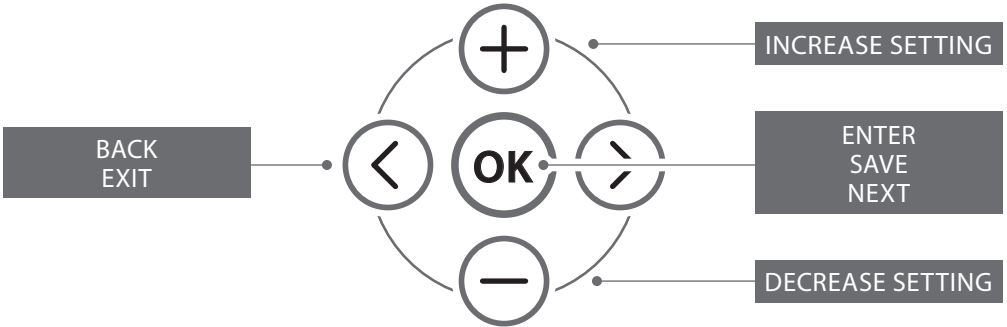

STEP 1 Set the Clock's Time of Day.

STEP 2 Choose whether there is existing copper in the pool.



For retrofitting existing pools, check copper levels prior to starting the system. If copper is existing at adequate levels of 0.2ppm – 0.7ppm, choose YES.



Did you know?

Typically all new pool installations will not contain copper. The system will run for one hour per one thousand litres for the initial start-up only to achieve correct copper levels. Time remaining will display on the screen for the customer and the pool can be used immediately.

STEP 3 Set the Pool Size (Litres).



Did you know?

The volume of water in the pool determines the run times of the system for both initial startup (injection of copper) and automatically sets the pump run times on a daily basis.

STEP 4 Choose Outdoor or Indoor Pool.



Did you know?

When selecting indoor pools during startup the system will automatically reduce the OXI output to 50% to avoid chlorine levels increasing. Once the startup process is complete, the OXI output will automatically default back to 100% and the ION SET will be set to 10%.



Consider reducing OXI output ongoing for indoor pools depending on usage.

STEP 5 Choose if a Naked pH Controller is connected.

* Note that this can be turned on at any time should a NKD-pH Controller be added at a later date through the main menu.

STEP 6 Is the Naked System controlled by an External Controller?

The Naked System is compatible with any external pool control system and will slave to the controller allowing it to switch the unit ON and OFF as programmed.

Selecting YES will set the Naked System into EXT.CONTROL mode and to the ON position. EX will be shown in the top right hand corner of the display.

ION SET will show at 100% and will automatically reduce to 20% once the initial copper is injected into the water.

Selecting NO will run the system and pump in ON mode for one hour per one thousand litres for the initial start-up to achieve the correct copper level in the pool. The LCD display will alternate and show the period of time remaining for the Startup process to complete.

The system will then switch to AUTO mode with the timers automatically set for daily operation including the pump and filter.

OXI Output Levels:

When using the External Controller Mode (EXT) the OXI will always be producing when unit is running so you may prefer to reduce OXI output to stop chlorine levels increasing, particularly with indoor or covered pools.

STARTUP | COMPLETE

If the option of copper was selected as YES, the system will go direct to AUTO mode with the correct timers set.

TIMER 1 (T1) = SANITISATION. Oxidiser, Ioniser and Pump are running.

TIMER 2 (T2) = SANITISATION & CIRCULATION. Oxidiser and Pump are running.



Did you know?

If you are retrofitting an existing pool that has high salt levels, the unit will automatically reduce the OXI output to compensate for the high conductivity ensuring correct output levels. Once the startup process is complete, the OXI output will go back to 100%.



Did you know?

- The Ioniser will always switch off based on the volume of water entered so that copper levels will not increase regardless of the Timers set.
- There is a Water Flow Sensor in the OXI Cell. Please make sure the pump is running whenever the Naked System is ON during Timers 1 and 2.

TECHNICAL SPECIFICATIONS

MODEL	NKD-M
Volts Input (Vac)	220-265
Amps Input (Aac)	0.4
Total Power Consumption (W)	93
OXI Volts Output (Vdc)	10.3
OXI Amps Output (Adc)	5
Chlorine (g/hr)	10 @ 800ppm TDS
Frequency (Hz)	50/60
Pump Outlet Rating (Aac)	9.4
Control Unit Dimensions (mm)	204W × 286H × 105D
OXI Cell Housing Dimensions (mm)	356L × 145D × 203H
ION Housing Dimensions (mm)	158L × 100D × 138H
Cell Design	9 Plate 140 × 60mm
Water Connection	40/50 mm
Water Flow Rate (L/min)	80 - 550
IP Rating	23
Unit Shipping Dimensions (mm)	452L × 430W × 206H
Net Weight (kg)	9.5

All measurements conducted at 26 degrees celcius water temperature and ideal TDS

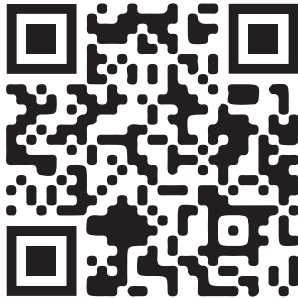

SCAN THIS CODE
TO GET THE
NAKED APP!

or visit your App Store and
search "Naked Pools"



Swimming as nature intended™

 1800 625 331

 support@naked-pools.com

 www.naked-pools.com